

*TB 9-6625-2270-24

DEPARTMENT OF THE ARMY TECHNICAL BULLETIN

CALIBRATION PROCEDURE FOR DIGITAL MULTIMETER AN/USM-486 (U) (FLUKE, MODEL 8050A/FM)

Headquarters, Department of the Army, Washington, DC
12 December 2007

Distribution Statement A: Approved for public release; distribution is unlimited.

REPORTING OF ERRORS AND RECOMMENDING IMPROVEMENTS

You can improve this manual. If you find any mistakes or if you know of a way to improve these procedures, please let us know. Mail your letter or DA Form 2028 (Recommended Changes to Publications and Blank Forms) directly to: Commander, U.S. Army Aviation and Missile Command, ATTN: AMSAM-MMC-MA-NP, Redstone Arsenal, AL 35898-5000. A reply will be furnished to you. You may also send in your comments electronically to our E-mail address: 2028@redstone.army.mil or by fax 256-842-6546/DSN 788-6546. For the World Wide Web use: <https://amcom2028.redstone.army.mil>. Instructions for sending an electronic 2028 can be found at the back of this manual.

SECTION		Paragraph	Page
I.	IDENTIFICATION AND DESCRIPTION		
	Test instrument identification	1	2
	Forms, records, and reports	2	2
	Calibration description	3	2
II.	EQUIPMENT REQUIREMENTS		
	Equipment required.....	4	3
	Accessories required	5	3
III.	CALIBRATION PROCESS		
	Preliminary instructions	6	4
	Equipment setup.....	7	4
	Dc voltage	8	4
	Ac voltage	9	6
	dB display	10	7
	Dc current.....	11	7
	Resistance.....	12	8
	Final procedure	13	8

SECTION I IDENTIFICATION AND DESCRIPTION

1. Test Instrument Identification. This bulletin provides instructions for the calibration of Digital Multimeter, AN/USM-486 (U) (Fluke, Model 8050A/FM). Drawing No. A3002840 and TM 11-6625-3055-14 were used as the prime data sources in compiling these instructions. The equipment being calibrated will be referred to as the TI (test instrument) throughout this bulletin.

a. Model Variations. None.

b. Time and Technique. The time required for this calibration is approximately 1 hour using the dc and low frequency technique.

2. Forms, Records, and Reports

a. Forms, records, and reports required for calibration personnel at all levels are prescribed by TB 750-25.

b. Adjustments to be reported are designated (R) at the end of the sentence in which they appear. Report only those adjustments made and designated with (R).

3. Calibration Description. TI parameters and performance specifications which pertain to this calibration are listed in table 1.

Table 1. Calibration Description

Test instrument parameters	Performance specifications ¹ (4 1/2 digit display)		
Dc voltage	Range: 0 to 1000 V (in 5 ranges) Accuracy: $\pm(0.05\%$ of reading + 3 digits)		
Ac voltage	Range: 0 to 750 V (in 5 ranges) Frequency: 20 Hz to 50 kHz ² Accuracy: $\pm(2.0\%$ of reading + 50 digits)		
dB display	Range: -60 dBm to +30 dBm Frequency: 20 Hz to 20 kHz Accuracy: $\pm(\text{dB})$ -60 to +10 dBm 0.50 +10 to +30 dBm. 0.25		
Ac current ³	Range: 0 to 2000 mA (in 5 ranges) Frequency: 20 Hz to 20 kHz Accuracy: $\pm(\%$ of reading + digits)		
	Range	Frequency	
		20 Hz to 10 kHz	10 to 20 kHz
	200 μA through 200 mA	1.0 + 25	2.0 + 50
	2000 mA	2.0 + 50	2.0 + 50
Dc current	Range: 0 to 2000 mA (in 5 ranges) Accuracy: $\pm(\%$ of reading + digits) Range: 200 μA through 200 mA 0.2 + 1 2000 mA 0.5 + 2		

See footnotes at end of table.

Table 1. Calibration Description - Continued

Test instrument parameters	Performance specifications ¹ (4 1/2 digit display)
Resistance	Range: 0 to 20 MΩ (in 6 ranges) Accuracy: ±(% of reading + digits) Range: 200Ω through 2.0 MΩ 0.1 + 1 20 MΩ 0.2 + 2

¹Specifications are based on procurement specifications and may not agree with manufacturer's or technical manuals.

²Volts/hertz product not to exceed 10⁷.

³Ac current verified during dc current check since same shunt resistors are utilized for both functions.

SECTION II EQUIPMENT REQUIREMENTS

4. Equipment Required. Table 2 identifies the specific equipment to be used in this calibration procedure. This equipment is issued with Secondary Transfer Calibration Standards Sets AN/GSM-286, AN/GSM-287 or AN/GSM-705. Alternate items may be used by the calibrating activity. The items selected must be verified to perform satisfactorily prior to use and must bear evidence of current calibration. The equipment must meet or exceed the minimum use specifications listed in table 2. The accuracies listed in table 2 provide a four-to-one ratio between the standard and TI. Where the four-to-one ratio cannot be met, the actual accuracy of the equipment selected is shown in parenthesis.

5. Accessories Required. The accessories required for this calibration are common usage accessories, issued as indicated in paragraph 4 above, and are not listed in this calibration procedure.

Table 2. Minimum Specifications of Equipment Required

Common name	Minimum use specifications	Manufacturer and model (part number)
CALIBRATOR	Dc voltage: Range: .19 to 1000 V Accuracy: ±.016 % Ac voltage: Range: 190 mV to 750 V Frequency: 20 Hz to 50 kHz Accuracy: ±(%) <u>Voltage</u> <u>Frequency</u> 100 mV through 190 V.....20 Hz to 50 kHz 0.566 750 V40 Hz to 10 kHz 0.667 20050 kHz..... 1.125 Dc current: Range: 189.61 μA to 1.9097 A Resistance: Range: 190 Ω to 19 MΩ Accuracy: ±(%) Resistance: 190Ω through 1.9 MΩ..... 0.026 19 MΩ 0.052 dBm: Range: -55 to +30 dBm Frequency: 1 kHz Accuracy: ±(dBm) -55 to -10 0.125 +15 and +30 0.0625	Fluke, Model 5720A (5720A) (p/o MIS-35947); w amplifier, Fluke 5725A/AR (5725A/AR)

SECTION III CALIBRATION PROCESS

6. Preliminary Instructions

a. The instructions outlined in paragraphs 6 and 7 are preparatory to the calibration process. Personnel should become familiar with the entire bulletin before beginning the calibration.

b. Items of equipment used in this procedure are referenced within the text by common name as listed in table 2.

c. Unless otherwise specified, verify the results of each test and, whenever the test requirement is not met, take corrective action before continuing with the calibration. Additional maintenance information is contained in TM 11-6625-3055-14.

d. Unless otherwise specified, all controls and control settings refer to the TI.

7. Equipment Setup

WARNING

HIGH VOLTAGE is used or exposed during the performance of this calibration. DEATH ON CONTACT may result if personnel fail to observe safety precautions. REDUCE OUTPUT(S) to minimum after each step within the performance check where applicable.

a. Remove protective cover from TI only to make adjustments and replace upon completion.

b. Connect TI to a 115 V ac source. Press **POWER** pushbutton to **ON** and allow at least 15 minutes for stabilization.

c. Set **DC/AC** pushbutton to **DC** (out) position.

d. Press **V** function pushbutton.

e. Press **200 mV** range pushbutton.

8. Dc Voltage

a. Performance Check

(1) Connect calibrator **OUTPUT** terminals to TI **V** and **COMMON** terminals.

(2) Press TI range pushbutton and set calibrator output as specified in table 3. If TI does not indicate within the specified limits, perform corresponding adjustment procedure.

Table 3. Dc Voltage

Test instrument range pushbutton	Calibrator output (V dc)	Test instrument indications		Adjustments
		Min	Max	
200 mV	0.19	189.88	190.12	b(1)
200 mV	-0.19	-189.88	-190.12	-----
2	1.9	1.8988	1.9012	b(2)
20	19	18.988	19.012	-----
200	190	189.88	190.12	b(3)
1000 DC	1000	999.2	1000.8	b(4)

b. Adjustments

- (1) Adjust R12 (fig. 1) for a TI indication of 190.00 (R).
- (2) Adjust R11 (fig. 1) for a TI indication of 1.9000 (R).
- (3) Adjust R5 (fig. 1) for a TI indication of 190.00 (R).
- (4) Adjust R6 (fig. 1) for a TI indication of 1000.0 (R).

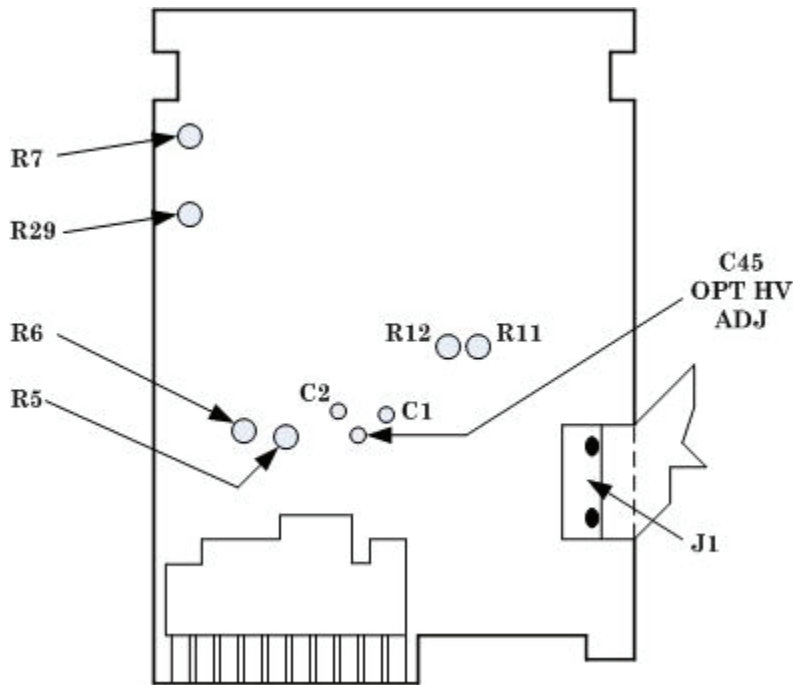

Figure 1. Adjustment locations.

9. Ac Voltage

a. Performance Check

- (1) Press **DC/AC** pushbutton to **AC** (in) and press the **200 mV** range pushbutton.
- (2) Set TI range and calibrator for voltages and frequencies listed in table 4. TI will indicate within the specified limits; if not, perform **b** below.

Table 4. Ac Voltage

Test instrument range pushbutton	Calibrator output		Test instrument indications	
	Voltage	Frequency	Min	Max
200 mV	190 mV	20 Hz	185.70	194.30
200 mV	190 mV	1 kHz	185.70	194.30
200 mV	190 mV	10 kHz	185.70	194.30
200 mV	190 mV	50 kHz	185.70	194.30
2	1.9 V	20 Hz	1.8570	1.9430
2	1.9 V	1 kHz	1.8570	1.9430
2	1.9 V	10 kHz	1.8570	1.9430
2	1.9 V	50 kHz	1.8570	1.9430
20	19 V	20 Hz	18.570	19.430
20	19 V	1 kHz	18.570	19.430
20	19 V	10 kHz	18.570	19.430
20	19 V	50 kHz	18.570	19.430
200	190 V	20 Hz	185.70	194.30
200	190 V	1 kHz	185.70	194.30
200	190 V	10 kHz	185.70	194.30
200	190 V	50 kHz	185.70	194.30
750 V AC	750 V	40 Hz	730.0	770.0
750 V AC	750 V	1 kHz	730.0	770.0
750 V AC	750 V	10 kHz	730.0	770.0
750 V AC	200 V	50 kHz	191.0	209.0

b. Adjustments

- (1) Set TI range to 2 and calibrator for a 1.9 V, 45 Hz output. Adjust R7 (fig. 1) for a TI indication of 1.9000 (± 5 digits) (R).
- (2) Set calibrator for a 100 mV, 45 Hz output. Adjust R29 (fig. 1) for a TI indication of 0.1000 (± 1 digit) (R).
- (3) Repeat (1) and (2) above until no further adjustments are required.
- (4) Set TI range to **20** and calibrator for a 19 V, 10 kHz output. Adjust C1 (fig. 1) for a TI indication of 19.000 (± 10 digits) (R).
- (5) Set TI range to **200** and calibrator for a 100 V, 10 kHz output. Adjust C2 (fig. 1) for a TI indication of 100.00 (± 5 digits) (R).
- (6) Repeat (4) and (5) above until no further adjustments are required.

NOTE

Do not perform (7) and (8) below unless an out-of-tolerance condition exists on the **750V AC** range.

(7) Set TI range to **750 V AC** and calibrator for a 750 V, 10 kHz output. Adjust C45 OPT HV ADJ (fig. 1) for a TI indication of 750.0 (± 10 digits) (R).

(8) Repeat (4), (5), and (7) above for the best compromise or until no further adjustments are required.

10. dB Display

a. Performance Check

(1) Connect calibrator **OUTPUT** terminals to TI **V** and **COMMON** terminals.

(2) Simultaneously press both **V** and **mA** function pushbuttons. Then press **200mV** range pushbutton.

(3) Set TI range and calibrator for dBm and frequency outputs listed in table 5. TI will indicate within the specified limits.

b. Adjustments. No adjustments can be made.

Table 5. dB Display

Test instrument range pushbutton	Calibrator output		Test instrument indications (dB)	
	Decibels (dBm)	Frequency (kHz)	Min	Max
200 mV	-55	1	-54.50	-55.50
200 mV	-20	1	-19.50	-20.50
2	-10	1	-9.50	-10.50
20	+15	1	+14.75	+15.25
200	+30	1	+29.75	+30.25

11. Dc Current

a. Performance Check

(1) Connect calibrator **OUTPUT** terminals to TI **mA** and **COMMON** terminals.

(2) Press TI **mA** function and **200 μ A** range pushbuttons. Set **DC/AC** pushbutton to **DC** (out).

(3) Set calibrator for an output of 190 μ A. TI will indicate between 189.61 and 190.39 μ A dc.

(4) Repeat technique of (2) through (4) above using settings and indications listed in table 6. TI will indicate within limits specified.

Table 6. Dc Current

Test instrument range pushbutton	Calibrator output	Test instrument indications (mA dc)	
		Min	Max
2	1.90 mA	1.8961	1.9039
20	19.0 mA	18.961	19.039
200	190 mA	189.61	190.39
2000	1.90 A	1890.3	1909.7

b. Adjustments. No adjustments can be made.

12. Resistance

a. Performance Check

(1) Connect calibrator **OUTPUT** terminals to TI **KΩ** and **COMMON** terminals. Press TI **KΩ** function and **200Ω** range pushbuttons.

(2) Set TI range and calibrator to the nominal resistance outputs as listed in table 7. At each resistance output adjust the calibrator output adjustment control knob for a calibrator control display reading equal to the TI indication. The calibrator control display **ERR** indication will be within the specified limits of table 7.

b. Adjustments. No adjustments can be made.

Table 7. Resistance

Test instrument range pushbutton	Calibrator	
	Output nominal resistance value	ERROR display indication ±(%)
200 Ω	100 Ω ¹	0.110
200 Ω	190 Ω	0.105
2	1.0 kΩ	0.110
2	1.9 kΩ	0.105
20	10 kΩ	0.110
20	19 kΩ	0.105
200	100 kΩ ²	0.110
200	190 kΩ	0.105
2000	1.0 MΩ	0.110
2000	1.9 MΩ	0.105
20 MΩ	10 MΩ	0.220
20 MΩ	19 MΩ	0.210

¹ Set calibrator **2 wire comp** to **ON**.

² Set calibrator **2 wire comp** to **OFF**.

13. Final Procedure

a. Deenergize and disconnect all equipment.

b. Annotate and affix DA label/form in accordance with TB 750-25.

By Order of the Secretary of the Army:

Official:



JOYCE E. MORROW
*Administrative Assistant to the
Secretary of the Army*

0728804

GEORGE W. CASEY, JR.
*General, United States Army
Chief of Staff*

Distribution:

To be distributed in accordance with the initial distribution number (IDN) 344421, requirements for calibration procedure TB 9-6625-2270-24.

INSTRUCTIONS FOR SUBMITTING AN ELECTRONIC 2028

The following format must be used if submitting an electronic 2028. The subject line must be exactly the same and all fields must be included; however, only the following fields are mandatory: 1, 3, 4, 5, 6, 7, 8, 9, 10, 13, 15, 16, 17, and 27.

From: "Whomever" whomever@redstone.army.mil
To: <2028@redstone.army.mil

Subject: DA Form 2028

1. **From:** Joe Smith
2. **Unit:** home
3. **Address:** 4300 Park
4. **City:** Hometown
5. **St:** MO
6. **Zip:** 77777
7. **Date Sent:** 19-OCT -93
8. **Pub no:** 55-2840-229-23
9. **Pub Title:** TM
10. **Publication Date:** 04-JUL-85
11. **Change Number:** 7
12. **Submitter Rank:** MSG
13. **Submitter FName:** Joe
14. **Submitter MName:** T
15. **Submitter LName:** Smith
16. **Submitter Phone:** 123-123-1234
17. **Problem:** 1
18. **Page:** 2
19. **Paragraph:** 3
20. **Line:** 4
21. **NSN:** 5
22. **Reference:** 6
23. **Figure:** 7
24. **Table:** 8
25. **Item:** 9
26. **Total:** 123
27. **Text**

This is the text for the problem below line 27.

